

Control valves

Manual control valves

Control valve 1/2 BSP, 60L/min, handle operated and return to center by spring. Relief valve

Page: 1/1

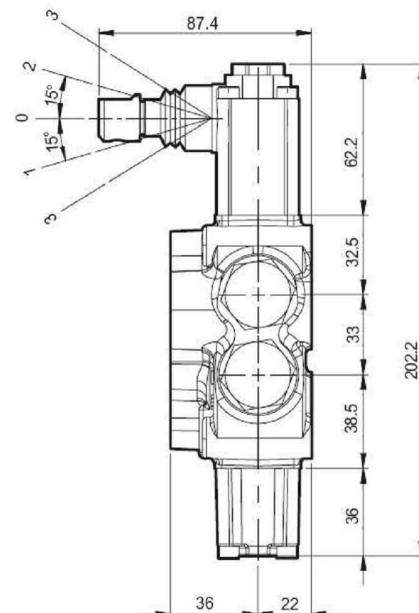
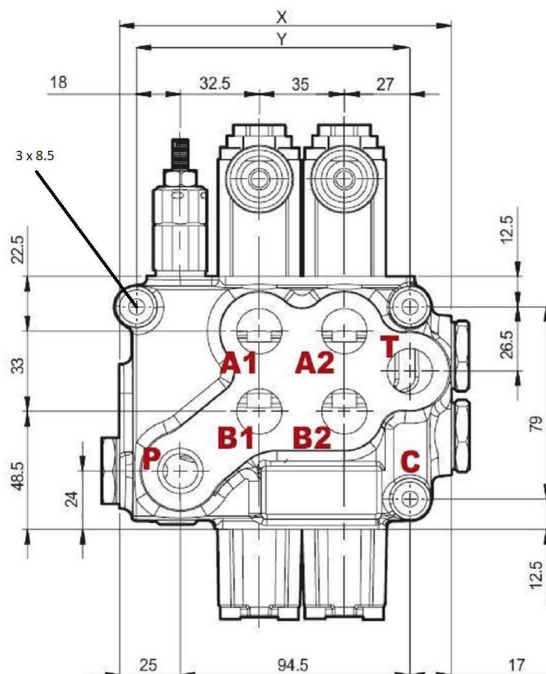
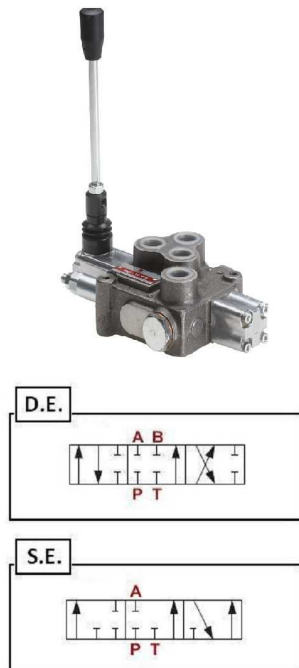

Max. Flow Rate 60 l/min

Operating Pressure (Maximum) 315 bar

Back Pressure (Maximum) on T port 25 bar

Ports 1/2" BSP

Relief Valve 120 bar (standar) / Regulation rate: 63-200 bar

Part n°	R1	Type	Max. flow (l/min)	Max. Press. (bar)	Levers	X	Y
YFM55/1 1/2 1P DE	1/2" BSP	D	60	315	1	101,5	78
YFM55/1 1/2 1P SE	1/2" BSP	S	60	315	1	101,5	78
YFM55/2 1/2 2P DD	1/2" BSP	D-D	60	315	2	136,5	113
YFM55/2 1/2 2P DS	1/2" BSP	D-S	60	315	2	136,5	113
YFM55/3 1/2 3P DDD	1/2" BSP	D-D-D	60	315	3	171,5	148
YFM55/3 1/2 3P DDS	1/2" BSP	D-D-S	60	315	3	171,5	148
YFM55/4 1/2 4P DDDD	1/2" BSP	D-D-D-D	60	315	4	206,5	183
YFM55/5 1/2 5P DDDDD	1/2" BSP	D-D-D-D-D	60	315	5	241,5	218
YFM55/6 1/2 6P DDDDDD	1/2" BSP	D-D-D-D-D-D	60	315	6	276,5	253