

R1000, R/SR 1400 / 1700, SR 1900 / 2000, VT 1708 / 2009B / 2014B / 2214B / 2514B / 2412B, VTO 2214B / 2514B / 2814B, SRO 2400

Descripción Description



Kit de eje adaptador Volvo que conecta el sincronizado de las tomas de fuerza 1140 y 1150 con el estriado interior de estas cajas de cambios.

Volvo adapter shaft Kit to connect the PTO splined shaft (for 1140 / 1150) with the female splined shaft of these gearboxes.

Datos Principales Main Data

| | | | |
|---|--------------------------------------|------------------|----------|
| Par nominal Torque (Nm) | Continuo Continuous | 600 | |
| | Intermitente Intermittent | 616 | |
| Potencia (1000 r.p.m.) Power (1000 r.p.m.) | | 63 C.V // 47 kW | |
| Lado de montaje Mounting position | | Posterior / Rear | |
| Relación motor - Toma de Fuerza Engine to PTO ratio | R1000, R1400, R1700, VT1708, VT2009B | 1: 0,700 | |
| | SR1400, SR17000, SR1900 | Larga High | 1: 0,880 |
| | | Normal | 1: 0,700 |
| | SR2000 | Larga High | 1: 0,820 |
| | | Normal | 1: 0,650 |
| | SRO2400 | Larga High | 1: 1,030 |
| | | Normal | 1: 0,820 |
| | VT2014B, VT2214B | Larga High | 1: 0,700 |
| | | Normal | 1: 0,880 |
| | VT2412B | Larga High | 1: 0,700 |
| | | Normal | 1: 0,903 |
| | VT2514B | Larga High | 1: 0,700 |
| | | Normal | 1: 0,880 |
| | VTO2214B, VTO2514B | Larga High | 1: 1,094 |
| | | Normal | 1: 0,880 |
| | VTO2814B | Larga High | 1: 1,12 |
| Normal | | 1: 0,890 | |
| L (mm) | Normal | Retarder | |
| | 265 | 300 | |
| Codigo Part Number | 110204 | 110504 | |
| Peso Weight (Kg) | 1,2 | 1,5 | |

Kit Volvo

110204

R1000, R/SR 1400 / 1700, SR 1900 / 2000, VT 1708 / 2009B / 2014B / 2214B / 2514B / 2412B, VTO 2214B / 2514B / 2814B, SRO 2400

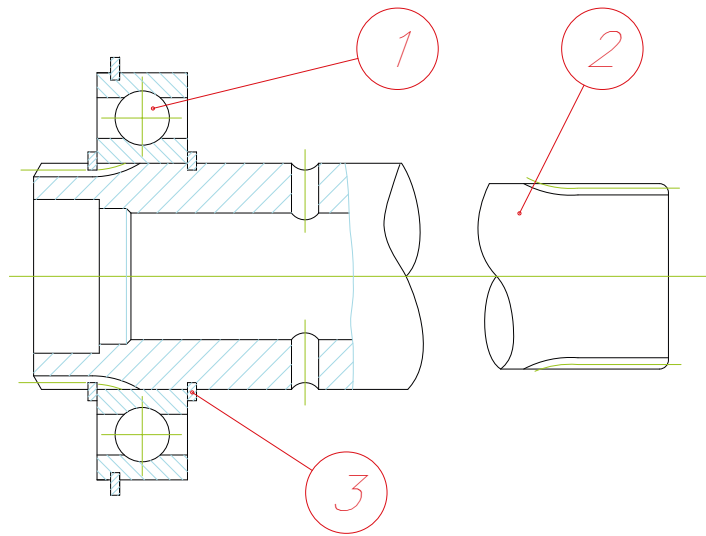

| | | Notas | Notes |
|---|----------------------------|-------|-----------------|
| 1 | Rodamiento Rigido de Bolas | 1 | Ball Bearing |
| 2 | Eje Adaptador | 2 | Adapter Shaft |
| 3 | Anillo elastico DIN 471 | 3 | Circlip DIN 471 |