

Serie TraXon



Descripción Description

Kit adaptador con estriado que conecta con el sincronizado de 14 dientes, para acoplar toda la gama de tomas de fuerza de la serie ZF S6-90.

Adapter Kit with splined shaft 14 teeth to connect all range of ZF S6-90 PTO's.

Datos Principales Main Data

Par nominal Torque (Nm)	840		
Potencia (1000 r.p.m.) Power (HP) 1000 r.p.m	120 CV // 89 Kw		
Peso Weight (Kg)	5		
Relación motor - Kit adaptador Engine to adapter kit ratio (*)	12TX-1410 /1610 /1810TD 12TX-2010 /2210TD 12TX-2420 /2620 /2820TD	/16.69-1.0	1: 0,76
	12TX-1610 /1810 /2010TO 12TX-2210 /2410 /2610TO 12TX-2820 /3020 /3220 /3420TO	/12.92-0.77	1: 1,26
	16TX-1640 /1840 /2040TD 16TX-2240 /2440 /2640TD 16TX-2840TD	/17.94-1.0	1: 0,72
	16TX-1840 /2040 /2240TO 16TX-2440 /2640 /2840TO 16TX-3040 /3240 /3440TO	/14.68-0.82	1: 1,08

Serie TraXon

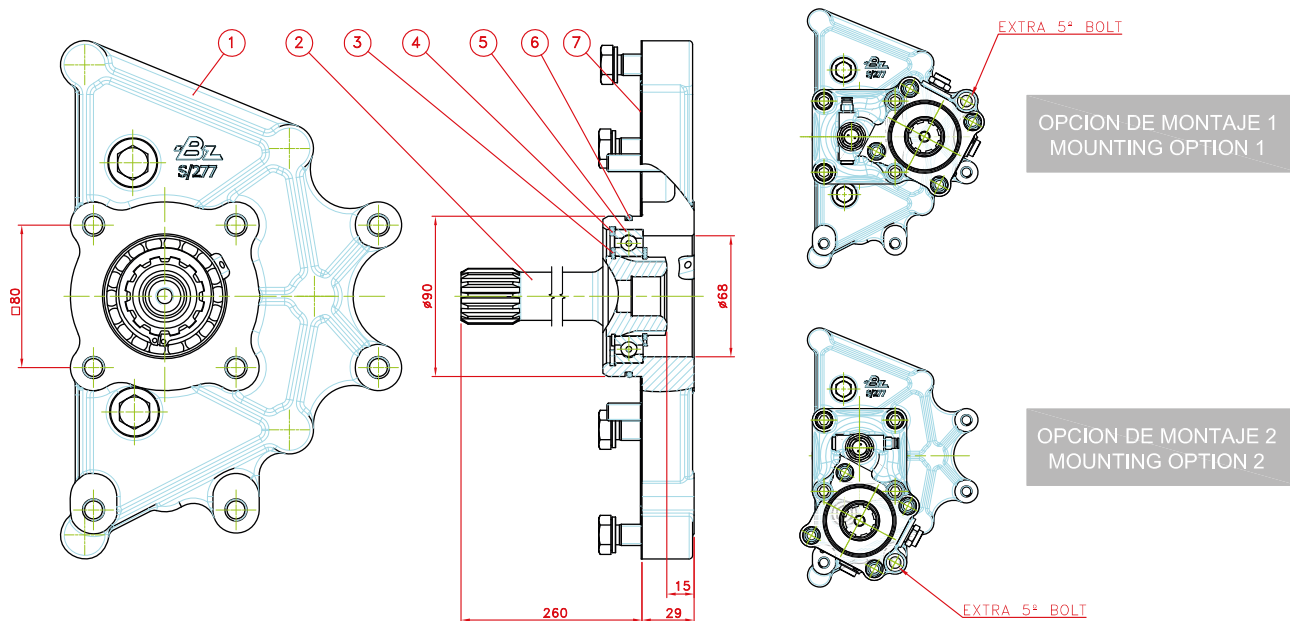

Notas Notes

1	Brida adaptadora	1	Adapter flange
2	Eje adaptador	2	Adapter shaft
3	Anillo elástico DIN 471	3	Circlip DIN 471
4	Anillo elástico DIN 472	4	Circlip DIN 472
5	Rodamiento de bolas 6009	5	Ball bearing 6009
6	Junta tórica	6	O-ring
7	Junta metálica	7	Steel gasket

(*) NOTA: La relación total a la salida de la toma de fuerza, se define al multiplicar la relación descrita, por la interna de la toma de fuerza correspondiente, de todas las versiones S6-90...

EJEMPLO: Caja de cambios 12TX-1410/16.69-1.0 kit adaptador + PTO S6-90 (Código 1010003)
Relación interna 1:1.32 Relación final: $0.76 \times 1.32 = 1.00$

NOTE: To get the correct ratio multiply the mentioned ratio by the internal ratio in all S6-90 releases.

EXAMPLE: Gearbox 12TX-1410/16.69-1.0 Adapter kit + PTO S6-90 (Part Number 1010003)
Internal ratio 1: 1.32 Final ratio: $0.76 \times 1.32 = 1.00$

Importante: Una bomba superior a 15 Kg necesita ser instalada sobre soportes

Warning: A pump with a weight over 15 Kg need to be supported by brackets.