

S5-50/90, S6-65/66/70/75/80/90, 6S-800/1000/1005/1200
TD/TO (Volvo ZTO 1006), 6AS 800/1000TO

Frontal - Neumático (1: 1,32)
Rear - Pneumatic



Descripción Description

Toma de fuerza de dos piñones, relación interna 1:1,32, para montar bombas ISO 4 taladros. Accionamiento neumático (Pistón Central), montaje sobre el registro posterior de la caja de cambios. Indicador de funcionamiento opcional.

Power Take-off two gears, internal ratio 1:1,32, to connect Iso 4 bolts pumps. Pneumatic shifting (Central Piston), mounting on rear 4 bolts-window of the Gearbox. Optional: Passing contact switch.

Datos Principales Main Data

Par nominal Torque (Nm)	Continuo Continuous	300
	Intermitente Intermittent	420
Potencia (1000 r.p.m.) Power (HP) 1000 r.p.m		42 C.V // 32 kW
Lado de montaje Mounting position		Posterior Rear
Sentido de giro de la bomba Pump rotation		Derecho ClockWise
Peso Weight (Kg)		11
Relación motor - Toma de Fuerza Engine to PTO ratio	ANEXO ATTACHMENT	

Códigos y Combinaciones Part Numbers and Combinations

Tipos de salida Output types		Plato Flange	Bomba Pump (DIN 5462)
Accionamiento neumático Pneumatic shifting		1010K02	1010K03

S5-50/90, S6-65/66/70/75/80/90, 6S-800/1000/1005/1200
 TD/TO (Volvo ZTO 1006), 6AS 800/1000TO

Frontal - Neumático (1: 1,32)

Rear - Pneumatic

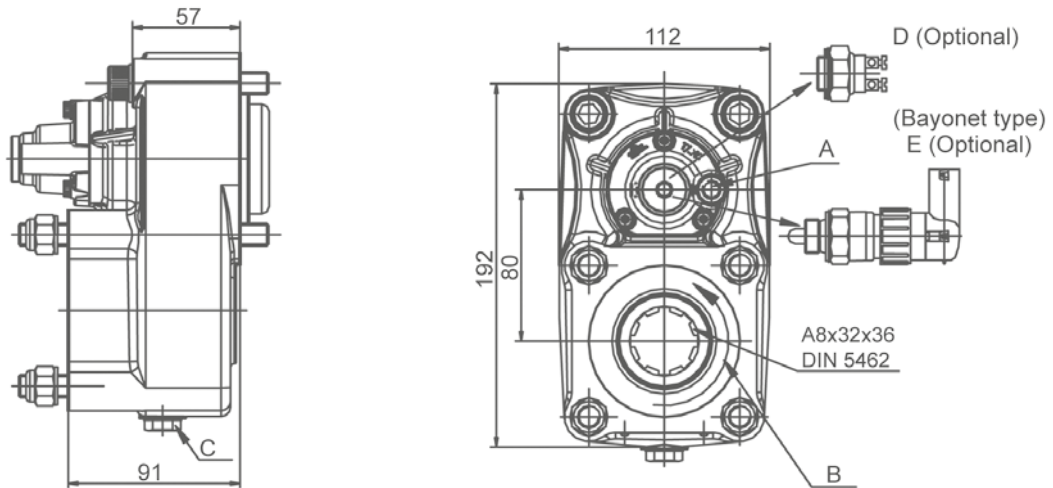

Notas		Notes	
A	Toma de aire, rosca 1/8" GAS	A	Engage PTO, thread 1/8" BSP
B	Sentido de giro	B	Rotation
C	Tapón de drenaje del aceite	C	Oil drain plug
D	Interruptor neumático. (100070018)	D	Pressure switch. P/N (100070018)
E	Interruptor de contacto. (9024999)	E	Passing contact switch. P/N 9024999

Tipos de Salida Output Types

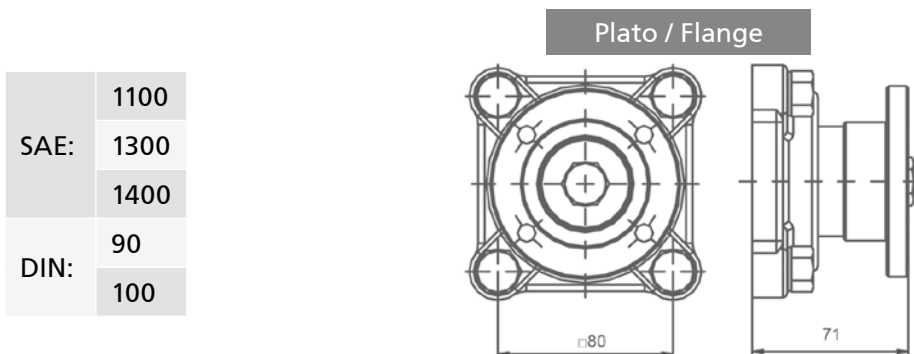

S5-50/90, S6-65/66/70/75/80/90, 6S-800/1000/1200 TD/TO
(Volvo ZTO 1006), 6AS 800/1000TO

Frontal - Neumático (1: 1,32)

Rear - Pneumatic

	CAJA GEARBOX	RELACIÓN RATIO	
S5-50	/ 5.30	1: 0,861	
	/ 5.50	1: 0,811	
	/ 6.20	1: 0,719	
	/ 6.61	1: 0,674	
	/ 6.61+GV80	Larga High	1: 0,842
	/ 5.30	Normal	1: 0,674
	/ 8.02	1: 0,557	
	/ 8.02+GV80/6.20	Larga High	1: 0,719
		Normal	1: 0,557
S5-90GP	/ GPA	1: 1,174	
S6-65	/ 6.37	1: 0,860	
	/ 6.70	1: 0,820	
	/ 7.0+GV70/7.67	Larga High	1: 0,602
		Normal	1: 0,482
	/ 7.40	1: 0,741	
	/ 7.52	1: 0,732	
	/ 9.00	1: 0,610	
	/ 7.97+GV80/6.70	Larga High	1: 0,819
		Normal	1: 0,694
	/ 9.00+GV80/6.70	Larga High	1: 0,819
		Normal	1: 0,611
	/ 9.00+GV80/7.52	Larga High	1: 0,732
	Normal	1: 0,611	
S6-66	/ 7.36-1.0	1: 0,690	
	/ 9.06-1.0	1: 0,550	
S6-70	/ 6.8	1: 0,679	
	/ 6.8+GV70/5.71	Larga High	1: 0,808
		Normal	1: 0,679
	/ 7.36	1: 0,630	
	/ 7.92	1: 0,582	
	/ 9.03	1: 0,511	
	/ 9.59	1: 0,482	
S6-75	/ 6.70+GV80/7.52	Normal	1: 0,819
		Corta Low	1: 0,732
S6-80	/ 5.03	1: 1,029	
	/ 5.66	1: 0,980	

	CAJA GEARBOX	RELACIÓN RATIO	
S6-80	/ 5.66+GV80/7.52	Larga High	1: 0,974
		Normal	1: 0,733
	/ 6.10	1: 0,908	
	/ 6.7	1: 0,820	
	/ 6.7+GV80/5.30	Larga High	1: 1,039
		Normal	1: 0,819
	/ 6.90	1: 0,679	
	/ 7.35	1: 0,728	
	/ 7.41	1: 0,743	
	/ 7.53	1: 0,732	
	/ 7.67	1: 0,710	
	/ 7.67+GV80/6.7	Larga High	1: 0,821
		Normal	1: 0,716
	/ 7.90	1: 0,693	
	/ 9.00	1: 0,610	
	/ 9.00+GV80/5.30	Larga High	1: 1,039
		Normal	1: 0,611
	/ 9.00+GV80/7.48	Larga High	1: 0,743
	Normal	1: 0,611	
/ 9.00+GV80/7.52	Larga High	1: 0,732	
	Normal	1: 0,611	
S6-90	/ 5.67	1: 0,990	
	/ 5.74	1: 0,980	
	/ 6.37	1: 0,980	
	/ 6.98	1: 0,807	
	/ 7.03	1: 0,796	
	/ 7.03+GV90/5.67	Larga High	1: 0,989
		Normal	1: 0,796
	/ 7.03+GV90/5.74	Larga High	1: 0,970
		Normal	1: 0,790
	/ 7.40	1: 0,759	
	/ 9.01	1: 0,620	
	/ 9.01+GV90/7.40	Larga High	1: 0,757
	Normal	1: 0,622	
6S800TO/6.58-0.78 (Volvo ZTO 1006)		1: 0,700	
6AS 800 TO/6.58-0.78		1: 0,700	
6AS1000TO/6.75-0.78		1: 0,700	
6S1000/1005 TO/6.75 - 0.78		1: 0,700	
6S1200TD/7.72 - 1.00		1: 0,713	
6S1200TO/6.75 - 0.83		1: 0,818	