

G131, G210, G211, G141-9, G221, G230, G231, G240, G241, G260, G280, G281, G330

Frontal - Neumático - Casquillo cierre bomba

Rear - Pneumatic - Closed pump cover

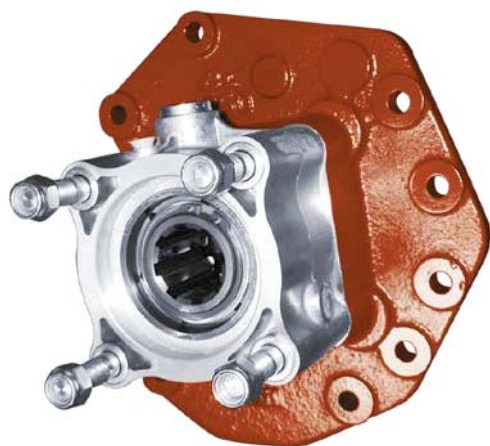

Descripción Description

Toma de fuerza 1:1 + brida (sin eje) para montar bombas ISO 4 taladros. Accionamiento neumático. Montaje sobre el registro posterior de 8 taladros de la caja de cambios. Indicador de funcionamiento y/o eje adaptador opcional. Base PTO + flange kit (without shaft), internal ratio 1:1 output ISO 4 bolts pumps. Pneumatic shifting. Mounting on rear 8 bolts-window of the Gearbox. Optional: Passing contact switch and adapter shaft.

Datos Principales Main Data

Par máximo Max. Torque (Nm)	700		
Potencia Máxima (1000 r.p.m.) Max. Power (1000 r.p.m.)	100 CV // 75 kW		
Lado de montaje Mounting position	Posterior Rear		
Sentido de giro de la bomba Pump rotation	Izquierdo CCW		
Peso Weight (Kg)	8.5		
Relación motor - Toma de Fuerza Engine to PTO ratio	G131-9/14.57-1.0	1: 0.738	
	G210-16/14.2-0.83	Normal Normal	1: 0.850
		Larga High	1: 1.030
	G141-9/14.57-1.0, G211-16/17.0, G231-16/17.0, G241-16K/17.0-1.0	Normal Normal	1: 0.710
		Larga High	1: 0.850
	G221-9/16.15-1.0	1: 0.74	
	G240-16/11.7, G280-16K/11.72-0.69, G280-16/11.72-0.69 NewAMT	Normal Normal	1: 1.030
		Larga High	1: 1.240
	G260-16/9.75-0.57	Normal Normal	1: 1.240
		Larga High	1: 1.500
G211-12K/14.93-1.0, G211-12/14.93-1.0 NewAMT, G281-12K/14.93-1.0, G281-12K/14.93-1.0, G281-12/14.93-1.0 NewAMT	Normal Normal	1: 0.810	
	Larga High	1: 1.030	
G230-12K/11.67-0.78, G230-12/11.67-0.78 NewAMT, G230-16S/14.2-0.83, G330-12K/11.64-0.78, G330-12/11.64-0.78 NewAMT	Normal Normal	1: 1.030	
	Larga High	1: 1.320	

Códigos y Combinaciones Part Numbers and Combinations

Kit toma de fuerza Base con brida Base PTO kit with flange ⁺		Kit de eje adaptador Adapter shaft kit	
Salida Plato Flange Output	07217K02	G131 ... G330, Z=16. L=252mm	700904
		G131 ... G330, Retarder. Z= 16. L=277mm	703704
Salida bomba Pump Output DIN 5462	07217K03	G281 Powershift 3, Z=16. L=293mm (Aquatarder)	7018104
		G281-12 Powershift 3, Z=16. L=268mm	7018304

G131, G210, G211, G141-9, G221, G230, G231, G240, G241, G260,
G280, G281, G330

Frontal - Neumático - Casquillo cierre bomba

Rear - Pneumatic - Closed pump cover

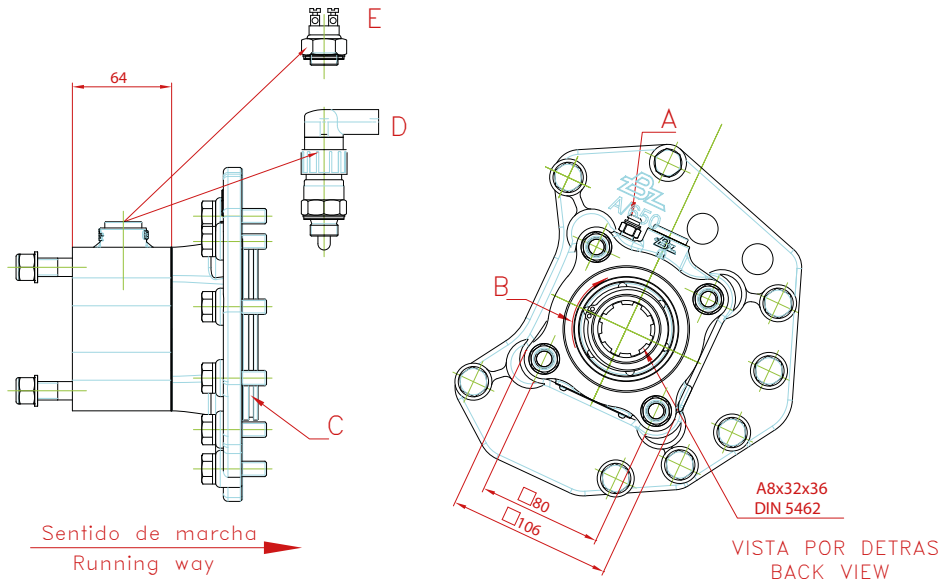

Notas Notes

	Notas	Notes
A	Toma de aire, rosca 1/8" GAS	A Air connection, thread 1/8" BSP
B	Sentido de giro	B Rotation
C	Casquillo cierre bomba de engrase	C Closed lubrication pump cover
D	Interruptor de contacto.(9024999)	D Passing contact switch. P/N 9024999
E	Interruptor neumático (100070018)	E Pressure switch. P/N (100070018)

Tipos de Salida Output Types

Adaptador Plato / Flange Adapter

FLANGE TYPE	Part Number	
SAE:	1100	7015504
	1300	
	1400	
DIN:	90	7015804
	100	
	100	

